

Small Wind Electric Systems

A U.S. Consumer's Guide

Introduction

Can I use wind energy to power my home? Spiraling utility bills, the need for uninterrupted service, and concerns over environmental impacts are generating increasing interest in small wind energy systems.

Small wind electric systems can make a significant contribution to our nation's energy needs. Although wind turbines large enough to provide a significant portion of the electricity needed by the average U.S. home generally require one acre of property or more, approximately 21 million U.S. homes are built on one-acre and larger sites, and 24% of the U.S. population lives in rural areas.

But will a small wind electric system work for you?

- Is there enough wind where you live?
- Do they allow tall towers in your neighborhood or rural area?
- Do you have enough space?
- How much electricity do you need or want to produce?
- Do you want to connect to the utility grid or be grid independent?
- Can you afford a wind energy system?
- What does it take to install and maintain a system?

These are just a few of the questions you need to answer before you can determine if a wind energy system will work for you. The purpose of this



Bergye Windpower/PIX01476

Homeowners, ranchers, and small businesses can use wind-generated electricity to reduce their utility bills. This grid-connected system installed for a home in Norman, Oklahoma, reduces the homeowner's utility bill by \$100 per month.

Contents

Introduction	1
First, How Can I Make My Home More Energy Efficient?	2
Is Wind Energy Practical for Me?	3
Is There Enough Wind on My Site?	4
What Size Wind Turbine Do I Need?	5
What are the Basic Parts of a Small Wind Electric System?	6
What Do Wind Systems Cost?	9
Where Can I Find Installation and Maintenance Support?	10
How Much Energy Will My System Generate?	11
How Do I Choose the Best Site for My Wind Turbine?	15
Can I Connect My System to the Utility Grid?	15
Can I Go "Off-Grid"?	19
Glossary of Terms	21
For More Information	22

guide is to provide you with the basic information you need to answer those questions and to address the many factors you need to consider to successfully install a small wind energy system and get maximum production.

Why Should I Choose Wind?

Wind energy systems are one of the most cost-effective home-based renewable energy systems. Depending on your wind resource, a small wind energy system can lower your electricity bill by 50% to 90%, help you avoid the high costs of having utility power lines extended to remote locations, prevent power interruptions, and it is nonpolluting. Over its life, a small residential wind turbine can offset approximately 1.2 tons of air pollutants and 200 tons of greenhouse gases (carbon dioxide and other gases that cause climate change).

How Do Wind Turbines Work?

Wind is created by the unequal heating of the Earth's surface by the sun. Wind turbines convert the kinetic energy in wind into mechanical power that runs a generator to produce clean, nonpolluting electricity. Today's turbines are versatile modular sources of electricity. Their blades are aerodynamically designed to capture the maximum energy from the wind. The wind turns the blades, which spin a shaft connected to a generator that makes electricity.

First, How Can I Make My Home More Energy Efficient?

Before you choose a wind system for your home, you should consider reducing your energy consumption by making your home or business more energy efficient. Reducing your energy consumption will significantly lower your utility bills and will

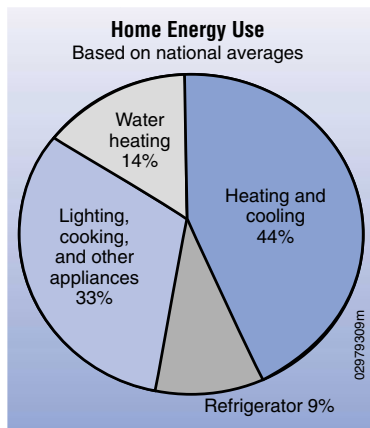

The largest portion of a utility bill for a typical house is for heating and cooling.

reduce the size of the home-based renewable energy system you need. To achieve maximum energy efficiency, you should take a whole-building approach. View your home as an energy system with interrelated parts, all of which work synergistically to contribute to the efficiency of the system. From the insulation in your home's walls to the lightbulbs in its fixtures, there are many ways you can make your home more efficient.

- Reduce your heating and cooling needs by up to 30% by investing just a few hundred dollars in proper insulation and weatherization products.
- Save money and increase comfort by properly maintaining and upgrading your heating, ventilation, and air-conditioning system.
- Install double-paned, gas-filled windows with low-emissivity (low-e) coatings to reduce heat loss in cold climates and spectrally selective coatings to reduce heat gain in warm climates.
- Replace your lights in high-use areas with fluorescents. By

replacing 25% of your lights, you can save about 50% of your lighting energy bill.

- When shopping for appliances, look for the ENERGY STAR® label. ENERGY STAR® appliances have been identified by the U.S. Environmental Protection Agency and U.S. Department of Energy as being the most energy-efficient products in their classes.
- For more information on how to make your home energy efficient, see Energy Savers, under For More Information.
- your property is in a remote location that does not have easy access to utility lines
- you are comfortable with long-term investments.

Zoning Issues

Before you invest in a wind energy system, you should research potential obstacles. Some jurisdictions, for example, restrict the height of the structures permitted in residentially zoned areas, although variances are often obtainable. Most zoning ordinances have a height limit of 35 feet. You can find out about the zoning restrictions in your area by calling the local building inspector, board of supervisors, or planning board. They can tell you if you will need to obtain a building permit and provide you with a list of requirements.

In addition to zoning issues, your neighbors might object to a wind machine that blocks their view, or they might be concerned about noise. Most zoning and aesthetic concerns can be addressed by supplying objective data. For example, the ambient noise level of most modern residential wind turbines is around 52 to 55 decibels. This means that while the sound

Is Wind Energy Practical for Me?

A small wind energy system can provide you with a practical and economical source of electricity if:

- your property has a good wind resource
- your home or business is located on at least one acre of land in a rural area
- your local zoning codes or covenants allow wind turbines
- your average electricity bills are \$150 per month or more



In Clover Valley, Minnesota, this 3-kW Whisper turbine on a 50-foot tower is connected to the utility grid to offset the farm's utility-supplied electricity.

of the wind turbine can be picked out of surrounding noise if a conscious effort is made to hear it, a residential-sized wind turbine is no noisier than your average refrigerator.

Is There Enough Wind on My Site?

Does the wind blow hard and consistently enough at my site to make a small wind turbine system economically worthwhile? That is a key question and not always easily answered. The wind resource can vary significantly over an area of just a few miles because of local terrain influences on the wind flow. Yet, there are steps you can take that will go a long way towards answering the above question.

As a first step, wind resource maps like the one in this publication can be used to estimate the wind resource in your region. The highest average wind speeds in the United States are generally found along seacoasts, on ridgelines, and on the Great Plains; however, many areas have wind resources strong enough to power a small wind turbine economically. The wind resource estimates on this map generally apply to terrain features that are well exposed to the wind, such as plains, hilltops, and ridge crests. Local terrain features may cause the wind resource at a specific site to differ considerably from these estimates. More detailed wind resource information, including the *Wind Energy Resource Atlas of United States*, published by the U.S. Department of Energy (DOE), can be found at the National Wind Technology Center web site at <http://www.nrel.gov/wind/> and the DOE Windpowering America web site at <http://www.eren.doe.gov/wind-poweringamerica/>.

Another way to indirectly quantify the wind resource is to obtain average

wind speed information from a nearby airport. However, caution should be used because local terrain influences and other factors may cause the wind speed recorded at an airport to be different from your particular location. Airport wind data are generally measured at heights about 20–33 ft (6–10 m) above ground. Average wind speeds increase with height and may be 15%–25% greater at a typical wind turbine hub-height of 80 ft (24 m) than those measured at airport anemometer heights. The National Climatic Data Center collects data from airports in the United States and makes wind data summaries available for purchase. Also, summaries of wind data from almost 1000 U.S. airports are included in the *Wind Energy Resource Atlas of the United States*.

Another useful indirect measurement of the wind resource is the observation of an area's vegetation. Trees, especially conifers or evergreens, can be permanently deformed by strong winds. This deformity, known as "flagging," has been used to estimate the average wind speed for an area. For more information on the use of "flagging" you may want to obtain A Siting Handbook for Small Wind Energy Conversion Systems (see For More Information).

Direct monitoring by a wind resource measurement system at a site provides the clearest picture of the available resource. A good overall guide on this subject is the *Wind Resource Assessment Handbook* (see For More Information). Wind measurement systems are available for costs as low as \$600 to \$1200. This expense may or may not be hard to justify depending on the exact nature of the proposed small wind turbine system. The measurement equipment must be set high enough to avoid turbulence created

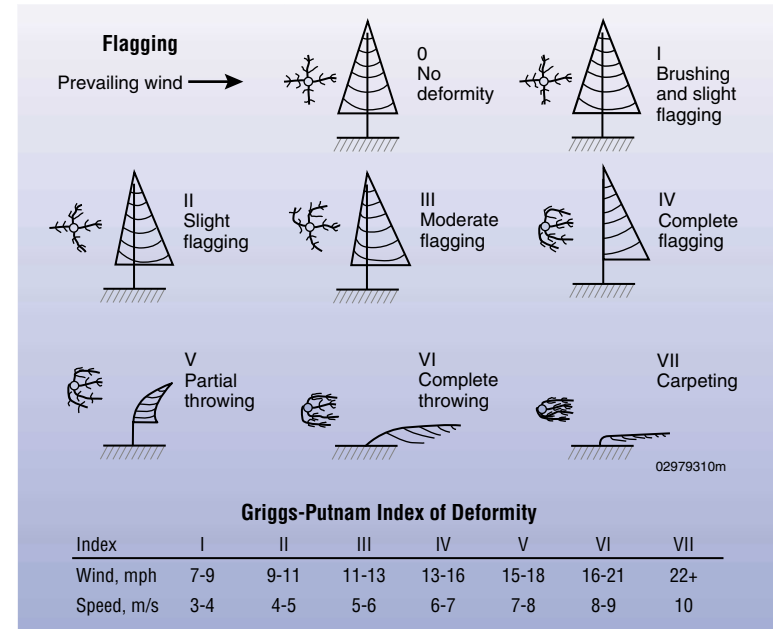

Flagging, the effect of strong winds on area vegetation, can help determine area wind speeds.

by trees, buildings, and other obstructions. The most useful readings are those taken at hub-height, the elevation at the top of the tower where the wind turbine is going to be installed. If there is a small wind turbine system in your area, you may be able to obtain information on the annual output of the system and also wind speed data if available.

What Size Wind Turbine Do I Need?

The size of the wind turbine you need depends on your application. Small turbines range in size from 20 watts to 100 kilowatts. The smaller or "micro" (20–500-watt) turbines are used for a variety of applications such as charging batteries for recreational vehicles and sailboats.

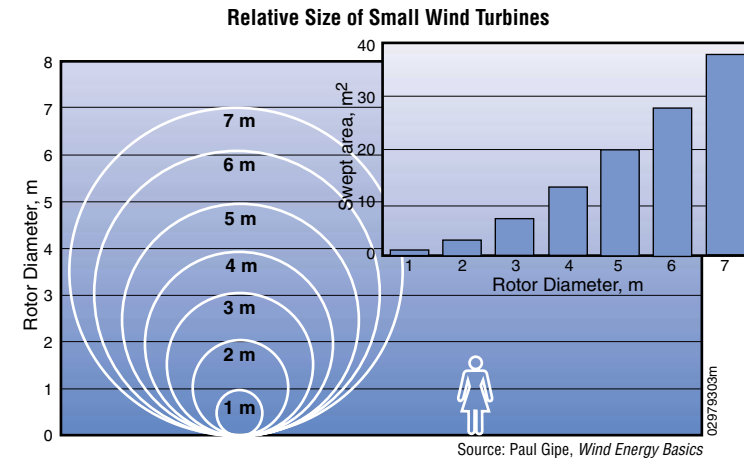

This 1 kW Whisper turbine provides direct AC power for the water pump for stock tanks on a ranch in Wheeler, Texas.



Elliott Beatty/Pix08681

One- to 10-kW turbines can be used for applications such as pumping water. Wind energy has been used for centuries to pump water and grind grain. Although mechanical windmills still provide a sensible, low-cost option for pumping water in low-wind areas, farmers and ranchers are finding the wind-electric pumping system to be a little more versatile and they can pump twice the volume for the same initial investment. In addition, mechanical windmills must be placed directly above the well, which may not take the best advantage of available wind resources, wind-electric pumping systems can be placed where the wind resource is the best and connected to the pump motor with an electric cable.

Turbines used for residential applications can range in size from 600 watts to 100 kW (100 kW for very large loads), depending on the amount of electricity you want to generate. For residential applications, you should establish an energy budget to help define the size of turbine you will need. Because energy efficiency is usually less expensive than energy

production, making your house more energy efficient first will probably be more cost effective because you may need a smaller wind turbine to meet your needs (see How Can I Make My Home More Energy Efficient?). Wind turbine manufacturers can help you size your system based on your electricity needs and the specifics of local wind patterns.

A typical home uses approximately 9400 kilowatt-hours (kWh) of electricity per year (about 780 kWh per month). Depending on the average wind speed in the area, a wind turbine rated in the range of 5 to 15 kilowatts (kW) would be required to make a significant contribution to this demand. A 1.5-kW wind turbine will meet the needs of a home requiring 300 kWh per month in a location with a 14-mile-per-hour (6.26-meters-per-second) annual average wind speed. The manufacturer can provide you with the expected annual energy output of the turbine as a function of annual average wind speed. The manufacturer will also provide information on the maximum wind speed at which the turbine is designed to operate safely. Most turbines have automatic overspeed-governing systems to keep the rotor from spinning out of control in very high winds, such as furling, pitching the blades, or stalling the blades. This information, along with your local wind speed and your energy budget, will help you decide which size turbine will best meet your electricity needs.

What are the Basic Parts of a Small Wind Electric System?

Home wind energy systems generally comprise a rotor, a generator mounted on a frame, a tail (usually), a tower, wiring, and the "balance of system" components: controllers, inverters,

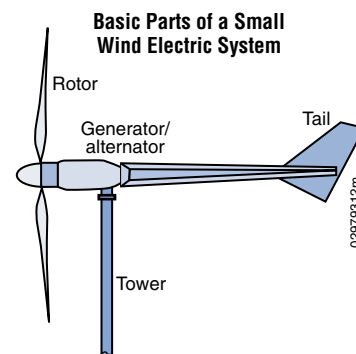

and/or batteries. Through the spinning blades, the rotor captures the kinetic energy of the wind and converts it into rotary motion to drive the generator.

Wind Turbine

Most turbines manufactured today are horizontal axis upwind machines that have two or three blades, which are usually made of a composite material such as fiberglass.

The amount of power a turbine will produce is determined primarily by the diameter of its rotor. The diameter of the rotor defines its "swept area," or the quantity of wind intercepted by the turbine. The turbine's frame is the structure onto which the rotor, generator, and tail are attached. The tail keeps the turbine facing into the wind. A few turbines on the market today are designed and tested to International Electrotechnical Commission (IEC) Standards. These turbines may be listed by a recognized testing agency, like Underwriter's Laboratories (UL).

Tower

Because wind speeds increase with height, the turbine is mounted on a tower. Generally speaking, the higher the tower, the more power the wind system can produce. The tower also raises the turbine above

the air turbulence that can exist close to the ground. A general rule of thumb is to install a wind turbine on a tower with the bottom of the rotor blades a least 30 feet (9 meters) above any obstacle that is within 300 feet (90 meters) of the tower. Relatively small investments in increased tower height can yield very high rates of return in power production. For instance, to raise a 10-kW generator from a 60-foot tower height to a 100-foot tower involves a 10% increase in overall system cost, but it can produce 25% more power.

There are two basic types of towers: self-supporting (free standing) and guyed. Most home wind power systems used a guyed tower. Guyed towers, which are the least expensive, can consist of lattice sections, pipe, or tubing depending on the design, and supporting wires. They are easier to install than self-supporting towers. However, because the guy radius must be one-half to three-quarters of the tower height, guyed towers require enough space to accommodate them. While tilt-down towers are more expensive they offer the consumer an easy way to perform maintenance. If the consumer decides to maintain the turbine herself, a tilt-down tower is far easier than a tower that must be climbed to perform maintenance. Tilt-down towers can also be lowered to the ground during hazardous weather such as hurri-

Tilt-down towers are much easier to maintain than guyed or free-standing towers.

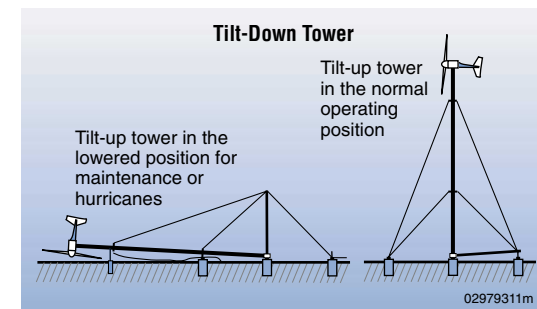

02979311m

canes. Aluminum towers are prone to cracking and should be avoided. Most turbine manufacturers provide wind energy system packages that include towers.

Mounting turbines on rooftops is not recommended. All wind turbines vibrate and transmit the vibration to the structure on which they are mounted. This can lead to noise and structural problems with the building, and the rooftop can cause excessive turbulence that can shorten the life of the turbine.

Balance of System

The parts that you need in addition to the turbine and the tower, or the balance of system parts, will depend on your application. Most manufacturers can provide you with a system package that includes all the parts you need for your application. For example, the parts required for water pumping will be much different than what you need for a residential application. The balance of system required will also depend on whether the system is grid-connected, stand-alone or part of a hybrid system. For a residential application, the balance of system parts may include a controller, storage batteries, a power conditioning unit

(inverter), and wiring. Some wind turbine controllers, inverters, or other electrical devices may be stamped by a recognized testing agency, like Underwriters Laboratories.

Stand-Alone Systems

Stand-alone systems (systems not connected to the utility grid) require batteries to store excess power generated for use when the wind is calm. They also need a charge controller to keep the batteries from overcharging. Deep-cycle batteries, such as those used for golf carts, can discharge and recharge 80% of their capacity hundreds of times, which makes them a good option for remote renewable energy systems. Automotive batteries are shallow-cycle batteries and should not be used in renewable energy systems because of their short life in deep-cycling operations.

In very small systems, direct current (DC) appliances operate directly off the batteries. If you want to use standard appliances that use conventional household alternating current (AC),



A Bergey Excel 10 kW wind turbine is part of a grid-connected hybrid system that reduces the utility power used by this home in Vermont. The balance of system for the turbine includes, from left to right, an inverter, breaker box, and powersync inverter.



Trudy Forsyth, NREL/PX09122 and PX09123



Southwest Windpower/PX09156

A Southwest WindPower Air 303 is the sole source of electricity for this remote home in northern Arizona.

however, you must install an inverter to convert DC electricity to AC. Although the inverter slightly lowers the overall efficiency of the system, it allows the home to be wired for AC, a definite plus with lenders, electrical code officials, and future homebuyers.

For safety, batteries should be isolated from living areas and electronics because they contain corrosive and explosive substances. Lead-acid batteries also require protection from temperature extremes.

Grid-Connected Systems

In grid-connected systems, the only additional equipment required is a power conditioning unit (inverter) that makes the turbine output electrically compatible with the utility grid. Usually, batteries are not needed.

What Do Wind Systems Cost?

A small turbine can cost anywhere from \$6,000 to \$22,000 installed, depending on size, application, and service agreements with the manufacturer. (AWEA says a typical home wind system costs approximately \$32,000; a comparable photovoltaic (PV) solar system would cost over \$60,000.)

A general rule of thumb for estimating the cost of a residential turbine is \$1,000 to \$3,000 per kilowatt. As a rule, wind energy becomes more cost effective as the wind turbines increase in diameter. Although small turbines cost less in initial outlay, they are proportionally more expensive. The cost of a residential wind energy system that comes with an 80-foot tower, batteries, and inverter, typically ranges from \$20,000 to \$40,000 for a 3 to 7.5 kW wind turbine.



Warren Grez, NREL/PX09165

Small wind turbines like this 10 kW Bergey Excel provide electricity for home, farm, and ranch applications.

Although wind energy systems involve a significant initial investment, they can be competitive with conventional energy sources when you account for a lifetime of reduced or altogether avoided utility costs. The length of the payback period—the time before the savings resulting from your system equal the cost of the system itself—depends on the system you choose, the wind resource on your site, electricity costs in your area, and how you use your wind system. For example, if you live in California and have received the 50% buydown of your small wind system, have net metering and an average annual wind of 6.7 m/s, your simple payback would be approximately 6 years.

Things to Consider When Purchasing a Wind Turbine

Once you decide you can legally install a wind energy system without alienating your neighbors, you can begin pricing systems and components. Comparatively shop for a wind system as you would any major purchase. Obtain and review the product literature from several manufacturers. As mentioned earlier, lists of manufacturers are available from the American Wind Energy Association (AWEA, see reference list), but not all small turbine manufacturers are members of AWEA. Check the Yellow Pages for wind energy system dealers in your area.

Once you have narrowed the field, research a few companies to be sure they are recognized wind energy businesses and that parts and service will be available when you need them. Call the Better Business Bureau to check on the company's integrity and ask for references of past customers with installations similar to the one you are considering. Ask the system owners about performance, reliability,

and maintenance and repair requirements, and whether the system is meeting their expectations. Also, find out how long the warranty lasts and what it includes.

Where Can I Find Installation and Maintenance Support?

The manufacturer/dealer should be able to help you install your machine. However, this is not rocket science. Many people elect to install the machines themselves. Before attempting to install your wind turbine, ask yourself the following questions:

- Can I pour a proper cement foundation?
- Do I have access to a lift or a way of erecting the tower safely?
- Do I know the difference between AC and DC wiring?
- Do I know enough about electricity to safely wire my machine?
- Do I know how to safely handle and install batteries?

If your answer to any of the above questions is no, you should probably choose to have your system installed by a system integrator or installer. Contact the manufacturer for help or call your state energy office and local utility for a list of local system installers. You can also check the yellow pages for wind energy system service providers. A credible installer will provide many services, permits, etc. Find out if the installer is a licensed electrician. Ask for references and check them out. And be sure to check with the Better Business Bureau.

Although small wind turbines are tough little machines, they do require some annual maintenance. Bolts and electrical connections should be

checked and tightened if necessary. The machines should be checked for corrosion and the guy wires for proper tension. In addition, you should check for and replace any worn leading edge tape on the blades, if appropriate. After 10 years, the blades or bearings may need to be replaced, but with proper installation and maintenance, the machine should last up to 20 years or longer.

If you do not have the expertise to maintain the machine or are afraid of heights, your installer may provide a service and maintenance program.

How Much Energy Will My System Generate?

Most U.S. manufacturers rate their turbines by the amount of power they can safely produce at a particular wind speed, usually chosen between 24 mph (10.5 m/s) and 36 mph (16 m/s). The formula for calculating the power from a wind turbine is:

$$\text{Power} = C_p \frac{1}{2} \rho A V^3$$

Where:

C_p = Power coefficient, ranging from 0.2–0.4, dimensionless (theoretical max = 0.59)

ρ = Air density, lb/ft³

A = Rotor swept area, or $\pi D^2/4$ (D is the rotor diameter in ft, $\pi = 3.1416$)

V = Wind speed, mph

This formula illustrates factors that are important to the performance of a wind turbine. Notice that the wind speed, V , has an exponent of 3 applied to it. This means that even a small increase in wind speed results in a large increase in power. That is why a taller tower will increase the productivity of any wind turbine by giving it access to higher wind speeds as

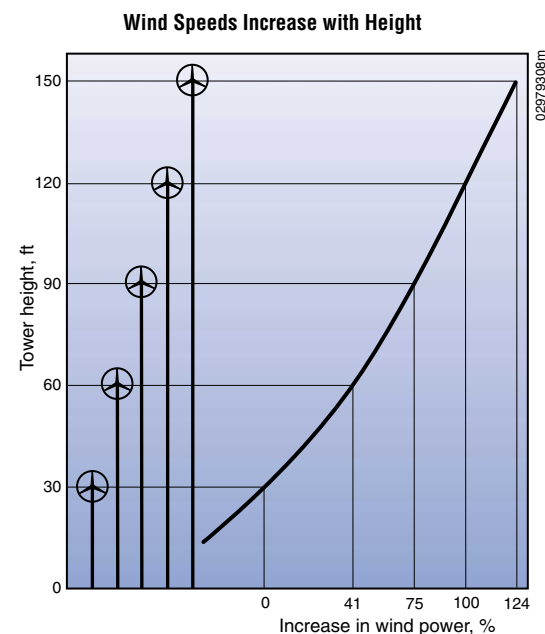

shown in the Wind Speed Increase with Height graph.

The rotor swept area, A , is important because the rotor is the part of the turbine that captures the wind energy. So, the larger the rotor, the more energy it can capture. The air density, ρ , changes slightly with air temperature and with elevation. The ratings for wind turbines are based on

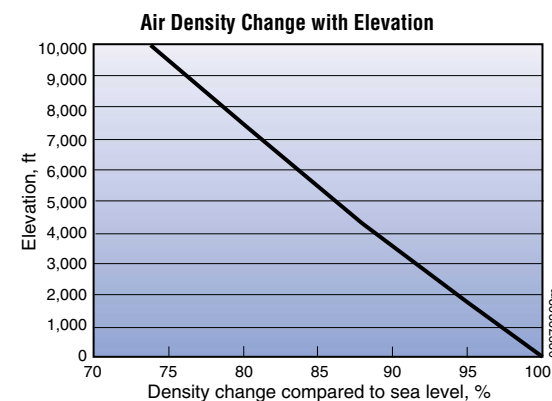

United States - Wind Resource Map

Yearly Electricity Production Estimated per m² of Rotor Swept Area for a Small Wind Turbine

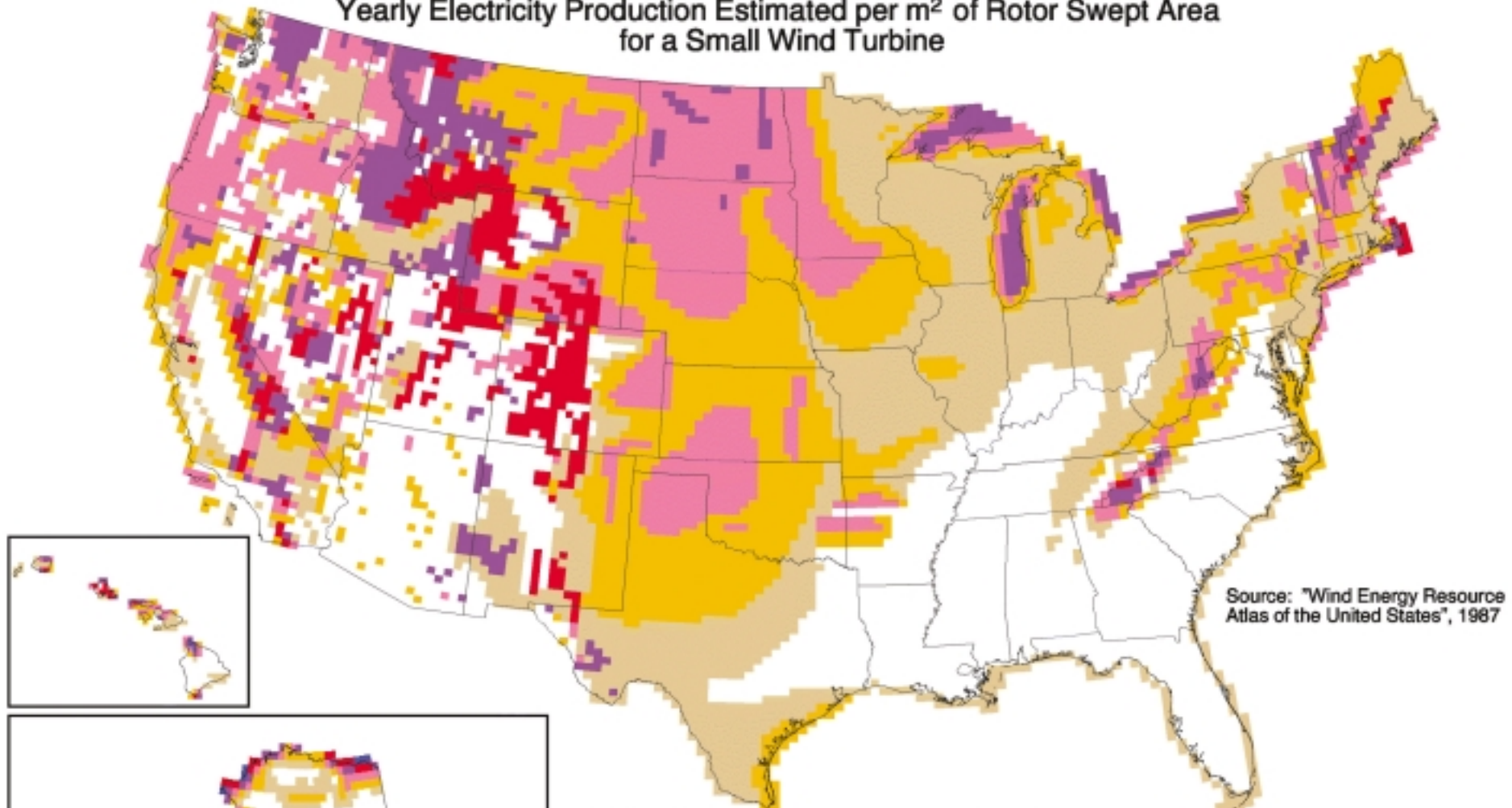

Source: "Wind Energy Resource Atlas of the United States", 1987

Small Wind Turbine Productivity Estimates*

Wind Power Class	Productivity per m ² of swept area** (kWh/year)	Wind Power Density at 33 ft (10 m) (W/m ²)	Wind Speed at 33 ft (10 m)	
			(mph)	(m/s)
1	< 350	<100	< 9.8	< 4.4
2	350 - 500	100 - 150	9.8 - 11.5	4.4 - 5.1
3	500 - 610	150 - 200	11.5 - 12.5	5.1 - 5.8
4	610 - 690	200 - 250	12.5 - 13.4	5.8 - 6.0
5	690 - 770	250 - 300	13.4 - 14.3	6.0 - 6.4
6	770 - 880	300 - 400	14.3 - 15.7	6.4 - 7.0
7	880 -1170	400 -1000	15.7 - 21.1	7.0 - 9.4

* Estimates are based on different models and sizes of wind turbines assuming a tower height of 80 ft (24 m).

** For systems of different sizes, multiply the estimated productivity by the total swept area of the turbine.

U.S. Department of Energy
National Renewable Energy Laboratory



03-APR-2001 1.1.8

standard conditions of 59° F (15° C) at sea level. A density correction should be made for higher elevations as shown in the Air Density Change with Elevation graph. A correction for temperature is typically not needed for predicting the long-term performance of a wind turbine.

While the calculation of wind power illustrates important features about wind turbines, the best measure of wind turbine performance is annual energy output. The difference between power and energy is that power (kilowatts [kW]) is the rate at which electricity is consumed, while energy (kilowatt-hours [kWh]) is the quantity consumed. An estimate of the annual energy output from your wind turbine, kWh/year, is the best

way to determine whether a particular wind turbine and tower will produce enough electricity to meet your needs.

A wind turbine manufacturer can help you estimate the energy production you can expect. They will use a calculation based on the particular wind turbine power curve, the average annual wind speed at your site, the height of the tower that you plan to use, and the frequency distribution of the wind—an estimate of the number of hours that the wind will blow at each speed during an average year. They should also adjust this calculation for the elevation of your site. Contact a wind turbine manufacturer or dealer for assistance with this calculation.

Spread sheet info

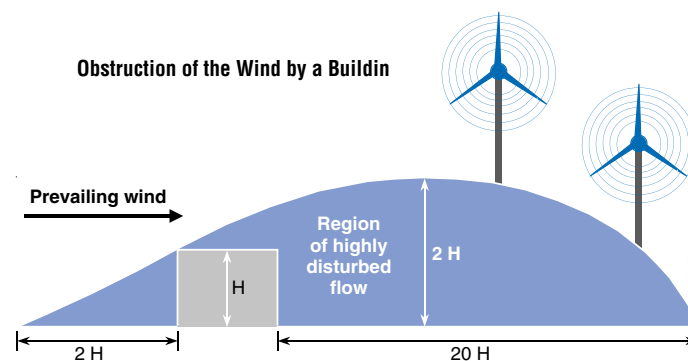

The farther you place your wind turbine from obstacles such as buildings or trees, the less turbulence you will encounter.

To get a preliminary estimate of the performance of a particular wind turbine, use the formula below.

$$AEO = 0.01328 D^2 V^3$$

Where:

AEO = Annual energy output, kWh/year

D = Rotor diameter, feet

V = Annual average wind speed, mph

How Do I Choose the Best Site for My Wind Turbine?

You can have varied wind resources within the same property. In addition to measuring or finding out about the annual wind speeds, you need to know about the prevailing directions of the wind at your site. If you live in complex terrain, take care in selecting the installation site. If you site your wind turbine on the top of or on the windy side of a hill, for example, you will have more access to prevailing winds than in a gully or on the leeward (sheltered) side of a hill on the same property. In addition to geologic formations, you need to consider existing obstacles such as trees, houses, and sheds, and you need to plan for future obstructions such as new buildings or trees that have not reached their full height. Your turbine

needs to be sited upwind of buildings and trees, and it needs to be 30 feet above anything within 300 feet. You also need enough room to raise and lower the tower for maintenance, and if your tower is guyed, you must allow room for the guy wires.

Whether the system is stand-alone or grid-connected, you will also need to take the length of the wire run into consideration. A substantial amount of electricity can be lost as a result of the wire resistance—the longer the wire run, the more electricity is lost. Using more or larger wire will also increase your installation cost. Your wire runs losses are greater when you have direct current (DC) instead of alternating current (AC) so if you have a long wire run it is advisable to invert DC to AC.

Can I Connect My System to the Utility Grid?

Small wind energy systems can be used in connection with an electricity distribution system and are called grid-connected systems. A grid-connected wind turbine can reduce your consumption of utility-supplied electricity for lighting, appliances, and electric heat. If the turbine cannot deliver the amount of energy you need, the utility makes up the difference. When the wind system produces

A grid-connected wind turbine can reduce your consumption of utility-supplied electricity.

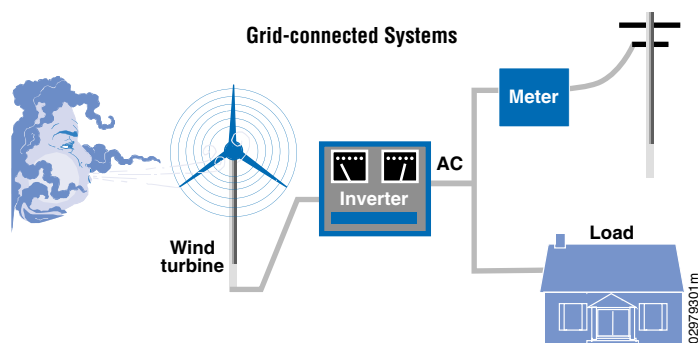

more electricity than the household requires, the excess is sent or sold to the utility.

Grid-connected systems can be practical if the following conditions exist:

- You live in an area with average annual wind speed of at least 10 miles per hour (4.5 meter per second).
- Utility-supplied electricity is expensive in your area (about 10 to 15 cents per kilowatt-hour).
- The utility's requirements for connecting your system to its grid are not prohibitively expensive.
- There are good incentives for the sale of excess electricity or for the purchase of wind turbines.

Federal regulations (specifically, the Public Utility Regulatory Policies Act of 1978, or PURPA) require utilities to connect with and purchase power from small (less than 80 MW) wind energy systems. However, you should contact your utility before connecting to their distribution lines to address any power quality and safety concerns. Your utility can provide you with a list of requirements for connecting your system to the grid. The American Wind Energy Association is another good source for information on utility interconnection require-

ments. The following information about utility grid connection requirements was taken from AWEA's Web site. For more detailed information, visit <http://www.awea.org/> or contact AWEA (see For More Information).

Net Metering

The concept of net metering programs is to allow the electric meters of customers with generating facilities to turn backwards when their generators are producing more energy than the customers' demand. Net metering allows customers to use their generation to offset their consumption over the entire billing period, not just instantaneously. This offset would enable customers with generating facilities to receive retail prices for more of the electricity they generate.

Net metering varies by state and by utility company, depending on whether net metering was legislated or directed by the Public Utility Commission. Net metering programs all specify a way to handle the net excess generation (NEG) in terms of payment for electricity and/or length of time allowed for NEG credit. If the net metering requirements define NEG on a monthly basis, the consumer can only get credit for their excess that month. But if the net

metering rules allow for annual NEG, the NEG credit can be carried for up to a year.

Most of North America gets more wind in the winter than in the summer. For people using wind energy to displace a large load in the summer like air-conditioning or irrigation water pumping, having an annual NEG credit allows them to produce NEG in the winter and be credited in the summer.

Safety Requirements

Whether or not your wind turbine is connected to the utility grid, the installation and operation of the wind turbine is probably subject to the electrical codes that your local government (city or county) or in some instances your state government has in place. The government's principal concern is with the safety of the facility, so these code requirements emphasize proper wiring and installation, and the use of components that have been certified for fire and electrical safety by approved testing laboratories, such as Underwriters Laboratories. Most local electrical codes requirements are based on the National Electrical Code (NEC), which is published by the National Fire Protection Association. As of 1999, the latest version of the NEC did not have any sections specific to the installation of wind energy facilities, consequently wind energy installations are governed by the generic provisions of the NEC.

If your wind turbine is connected to the local utility grid so that any of the power produced by your wind turbine is delivered to the grid, then your utility also has legitimate concerns about safety and power quality that need to be addressed. The utility's principal concern is that your wind turbine automatically stops delivering

any electricity to its power lines during an outage. Otherwise line workers and the public, thinking that the line is "dead," might not take normal precautions and might be hurt or even killed by the power from your turbine. Another concern among utilities is that the power from your facility synchronize properly with the utility grid, and that it match the utility's own power in terms of voltage, frequency, and power quality.

A few years ago, some state governments started developing new standardized interconnection requirements for small renewable energy generating facilities (including wind turbines). In most cases the new requirements have been based on consensus-based standards and testing procedures developed by independent third-party authorities, such as the Institute of Electrical and Electronic Engineers and Underwriters Laboratories.

Interconnection Requirements

Most utilities and other electricity providers require you to enter into a formal agreement with them before you interconnect your wind turbine with the utility grid. In states that have retail competition for electricity service (e.g., your utility operates the local wires, but you have a choice of electricity provider) you may have to sign a separate agreement with each company. Usually these agreements are written by the utility or the electricity provider. In the case of private (investor-owned) utilities, the terms and conditions in these agreements must be reviewed and approved by state regulatory authorities.

Insurance

Some utilities require small wind turbine owners to maintain liability insurance in amounts of \$1 million or more. Utilities argue these require-



ments are necessary to protect them from liability for facilities they do not own and have no control over. Others argue that the insurance requirements are excessive and unduly burdensome, making wind energy uneconomical. In the 21 years since utilities have been required to allow small wind systems to interconnect with the grid there has never been a liability claim, let alone a monetary award, relating to electrical safety.

In six states (California, Maryland, Nevada, Oklahoma, Oregon, and Washington), laws or regulatory authorities prohibit utilities from imposing any insurance requirements on small wind systems that qualify for "net metering." In at least three other states (Idaho, New York, Virginia) regulatory authorities have allowed utilities to impose insurance requirements, but have reduced the required coverage amounts to levels consistent with conventional residential or commercial insurance policies (e.g., \$100,000 to \$300,000). If your utility requires insurance amounts that seem

excessive, you may want to protest these requirements to regulatory authorities (in the case of private investor-owned utilities) or to the utility's governing board (in the case of publicly-owned utilities).

Indemnification

An indemnity is an agreement between two parties where one agrees to secure the other against loss or damage arising from some act or some assumed responsibility. In the context of customer-owned generating facilities, utilities often want customers to indemnify them for any potential liability arising from the operation of the customer's generating facility. Although the basic principle is sound—utilities should not be held responsible for property damage or personal injury attributable to someone else—indemnity provisions should not favor the utility but should be fair to both parties. Look for language that says, "each party shall indemnify the other . . ." rather than "the customer shall indemnify the utility . . ."

Connecting to the Utility Grid— A Success Story

This 10-kW Bergey wind turbine, installed on a farm located in Southwestern Kansas in 1978, produces an average 1700–1800 kilowatt-hours per month, reducing the user's monthly utility bills by approximately 50%. The turbine cost about \$20,000 when it was installed and, since then the cost for operation and maintenance has been about \$50 per year. The only unscheduled maintenance activity over the years was repair to the turbine required as a result of damage caused by a lightning strike. Insurance covered all but \$500 of the \$9000 cost of damages. The basic system parts include:

Bergey XL.10 wind turbine
100-foot free-standing lattice tower
Inverter

Warren Greitz, NREUP/08634

A grid-connected wind turbine can reduce your consumption of utility-supplied electricity for lighting, appliances, and electric heat.



Hybrid Power Systems

Combine multiple sources to deliver non-intermittent electric power

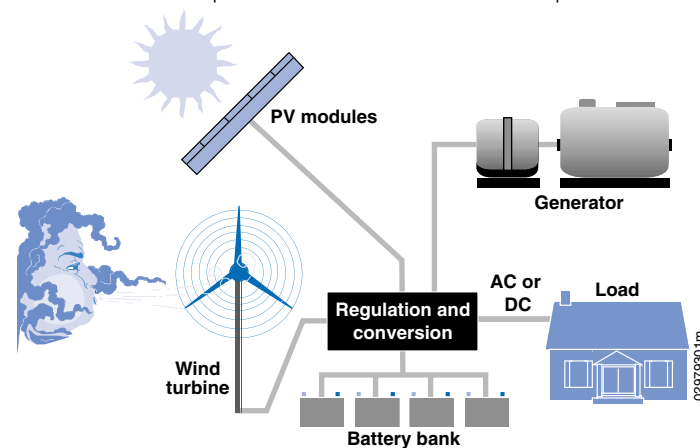

A hybrid system that combines a wind system with a solar and/or diesel generator can provide reliable off-grid power around the clock.

Customer Charges

Customer charges can take a variety of forms, including interconnection charges, metering charges, and standby charges, among others. You should not hesitate to question any charges that seem inappropriate to you. Federal law (Public Utility Regulatory Policies Act of 1978, or PURPA, Section 210) prohibits utilities from assessing discriminatory charges to customers who have their own generation facilities.

Can I Go "Off-Grid"?

Hybrid Systems

Off-grid hybrid wind energy systems can be appropriate for homes, farms or even entire communities (a co-housing project, for example) that are far from the nearest utility lines. According to many renewable energy experts, a "hybrid" system that combines wind and photovoltaic (PV) technologies offers several advantages over either single system. In much of the United States, wind speeds are low in the summer when the sun shines brightest and longest. The wind is strong in the winter when

there is less sunlight available.

Because the peak operating times for wind and PV occur at different times of the day and year, hybrid systems are more likely to produce power when you need it. (For more information on solar electric or PV systems, contact the Energy Efficiency and Renewable Energy Clearinghouse—see For More Information.)

For the times when neither the wind nor the PV modules are producing, most hybrid systems provide power through batteries and/or an engine-generator powered by fossil fuels. If the batteries run low, the engine-generator can provide power and recharge the batteries. Adding a fossil-fuel-powered generator makes the system more complex, but modern electronic controllers can operate these systems automatically. Adding an engine-generator can also reduce the size of the other components needed for the system. Keep in mind that the storage capacity must be large enough to supply electrical needs during non-charging periods. Battery banks are typically sized to

supply the electric load for one to three days.

An off-grid hybrid system may be practical for you if:

- You live in an area with average annual wind speed of at least 9 miles per hour (4.0 meters per second).
- A grid connection is not available or can only be made through an expensive extension. The cost of

running a power line to a remote site to connect with the utility grid can be prohibitive, ranging from \$15,000 to more than \$50,000 per mile, depending on terrain.

- You would like to gain energy independence from the utility.
- You would like to reduce the environmental impact of electricity production.

Living Off-Grid—A Success Story

This home, built near in Ward, Colorado (at an elevation of 9000 feet), has been off-grid since it was built in 1972. When the house was built, the nearest utility was over a mile away, and it would have cost between \$60K–\$70K (based on 1985 rates) to connect to the utility lines. The owners decided to install a hybrid electric system powered by wind, solar, and a generator for a cost of about \$19,700. The parts of the system include:

Bergey 1.5 kW wind turbine, 10-ft (3-m) diameter rotor, 70-ft. (21-m) tower

Solarex PV panels, 480 watts

24 VDC battery bank, 375 Ah

Trace sine wave inverter, 120 VAC, 1 phase, 4 kW

Onan propane-fueled generator, 6.5 kW rated (3 kW derated for altitude)

The Bergey wind turbine listed above is the fourth used turbine to be purchased for this system as a result of the extreme winds at this site.

Electric appliances in the home include television, stereo, two computers, toaster, blender, vacuum cleaner, and hair dryer. The largest electric loads are created by a well pump and washing machine. The generator runs about 20% of the time, particularly when the washing machine is in use. Propane serves the other major loads in the home: range, refrigerator, hot water, and space heat. Solar collectors on the roof provide pre-heating for the hot water.

Electricity for this off-grid home near Ward, Colorado, is provided by a wind/PV/diesel hybrid system.



Jim Green, NREL/PX02796

Glossary of Terms

Airfoil—The shape of the blade cross-section, which for most modern horizontal axis wind turbines, is designed to enhance the lift and improve turbine performance.

Anemometer—Device to measure the wind speed.

Average wind speed—The mean wind speed over a specified period of time.

Blades—The aerodynamic surface that catches the wind.

Brake—Various systems used to stop the rotor from turning.

Converter—See Inverter.

Cut-in wind speed—Wind speed at which a wind turbine begins to generate electricity.

Cut-out wind speed—Wind speed at which a wind turbine ceases to generate electricity.

Density—Mass per unit of volume.

Downwind—On the opposite side from the direction for which the wind is blowing.

Furling—A passive protection for the turbine where most typically the rotor folds either up or around the tail vane.

Green energy—Energy produced by non-polluting methods, such as wind, solar, hydro, or geothermal energy.

Grid—Utility distribution system. The network that connects electricity generators to electricity users.

HAWT—Horizontal Axis Wind Turbine.

Inverter—Device which converts direct current (DC) to alternating current (AC).

kW—Kilowatt, a measure of power for electrical current (1000 watts).

kWh—Kilowatt-hour, a measure of energy equal to the use of one kilowatt in one hour.

MW—Megawatt, a measure of power (1,000,000 watts).

Nacelle—The body of a propeller-type wind turbine, contains the gearbox, generator, blade hub and other parts.

O&M Costs—Operation and maintenance costs.

Power Coefficient The ratio of the power extracted by a wind turbine to the power available in the wind stream.

Power curve—Chart of a wind turbine's power output across a range of wind speeds.

PUC—Public Utility Commission, state agency which regulates utilities. In some areas known as Public Service Commission (PSC).

PURPA Public Utility Regulatory Policies Act (1978), 16 U.S.C. § 2601.18 CFR §292 refers to small generator.

Rated output capacity—The output power of a wind machine operating at the rated wind speed.

Rated wind speed—The lowest wind speed at which the rated output power of a wind turbine is produced.

Rotor—The rotating part of a wind turbine, including either the blades and blade assembly or the rotating portion of a generator.

Rotor diameter—The diameter of the circle swept by the rotor.

Rotor speed—Revolutions per minute of the wind turbine rotor.

Start-up wind speed—Wind speed at which a wind turbine rotor will begin to spin. See also cut-in wind speed

Swept area—Area swept by the turbine rotor, $A = \pi R^2$, where R is the radius of the rotor.

Tip speed ratio—Speed at the tip of the rotor blade as it moves through the air divided by the wind velocity. This is typically a design requirement for the turbine.

Turbulence—Changes in wind speed and direction, frequently caused by obstacles.

Upwind—On the same side as the direction from which the wind is blowing—windward.

VAWT—Vertical Axis Wind Turbine.

Wind farm—A group of wind turbines, often owned and maintained by one company. Also known as a wind power plant.

Yaw—The movement of the tower top turbine that allows the turbine to stay into the wind.

For More Information

Books

A Siting Handbook for Small Wind Energy Conversion Systems. H. Wegley, J. Ramsdell, M. Orgill and R. Drake, Report No. PNL-2521 Rev.1, 1980; available from National Technical Information Service, 5285 Port Royal Rd., Springfield, VA 22151)

Energy Savers Tips on Saving Energy and Money at Home—A consumer's guide for saving energy and reducing utility bills. Available from U.S. Department of Energy's Energy Efficiency and Renewable Energy Clearinghouse (EREC), P.O. Box 3048, Merrifield, Virginia 22116. (800) 363-3732. www.eren.doe.gov/consumerinfo/energy_savers.

Wind Energy Basics by Paul Gipe—A comprehensive guide to modern small wind technology. Available through AWEA. (202) 383-2500. <http://awea.org> and Chelsea Green Publishing Company, White River Junction, Vermont. 1999. ISBN 1-890132-07-01.

Wind Energy Resource Atlas of the United States by D. Elliott et al. Available from the American Wind Energy Association, 122 C. Street N.W., Washington D.C. 20001. <http://rredc.nrel.gov/wind/pubs/atlas>

Wind Power for Home and Business by Paul Gipe—A comprehensive guide to modern small wind technology. Available through AWEA. (202) 383-2500. <http://awea.org> Chelsea Green Publishing Company, White River Junction, Vermont. 1999. ISBN - 0-930031-64-4.

Wind Resource Assessment Handbook: Fundamentals for Conducting a Successful Monitoring Program—This handbook presents industry-accepted guidelines for planning and conducting a wind resource measurement program. These guidelines, which are detailed and highly technical, emphasize the tasks of selecting, installing, and operating wind measurement equipment, as well as collecting and analyzing the associated data. Prepared by AWS Scientific, Inc., 3 Washington Square, Albany, NY 12205.

Government Agencies

Energy Efficiency and Renewable Energy Clearinghouse, P.O. Box 3048, Merrifield, Virginia 22116 800-DOE-EREC (363-3732).

National Climatic Data Center, Federal Building, 151 Patton Avenue, Asheville, North Carolina, 28801-5001. (828) 271-4800. Fax (828) 271-4876. <http://www.ncdc.noaa.gov>

U.S. Department of Commerce, National Technical Information Service, 5285 Port Royal Road, Springfield, Virginia 22161. (800) 553-6847. <http://www.ntis.gov/ordering.htm>

Non-Government Organizations

American Wind Energy Association, 122 C Street, N.W. 4th Floor, Washington, D.C. 20001. (202)383-2500. www.awea.org

Solar Energy International—Short courses on renewable energy and sustainable development, in Carbondale, Colorado. (970) 963-8855. <http://www.solarenergy.org>.

Periodicals

"Apples and Oranges" by Mick Sagrillo—A comprehensive comparison of available small wind turbines. On Home Power Magazine Web site: <http://www.homepower.com>

Home Power Magazine—The definitive bimonthly magazine for the homemade power enthusiast. (800)707-6586 or on the Web at: <http://www.homepower.com>

Videos

An Introduction to Residential Wind Systems with Mick Sagrillo—A 63-minute video answering questions most often asked by homeowners as they consider purchasing and installing their own wind power systems. Order from AWEA (202) 383-2500, <http://www.awea.org>

Web Sites

AWEA Small Wind Systems Web site—Includes answers to frequently asked questions and information on U.S. manufacturers. <http://www.awea.org/smallwind.html>

Database of State Incentives for Renewable Energy—On the Web at <http://www.dcs.ncsu.edu/solar/dsire/dsire.html>

Green Power Network Net Metering Web Site—Net metering programs are now available in 30 states. Visit this DOE Web site for information: <http://www.eren.doe.gov/greenpower/netmetering>

Information on Home-Built Small Wind Turbines—<http://www.picoturbine.com>

Small Wind "Talk" on the Web—AWEA's Home Energy Systems electronic mailing list is designed as a forum for the discussion of small-scale energy systems that include wind. To subscribe, send a subscription request awea-wind-home-subscribe@egroups.com.

Wind Energy for Homeowners—This Web site discusses things you should consider before investing in a small wind energy system and provides basic information about the systems. <http://www.eren.doe.gov/wind/homeowner.html>

